

# C-Lube Linear Way MV

MV

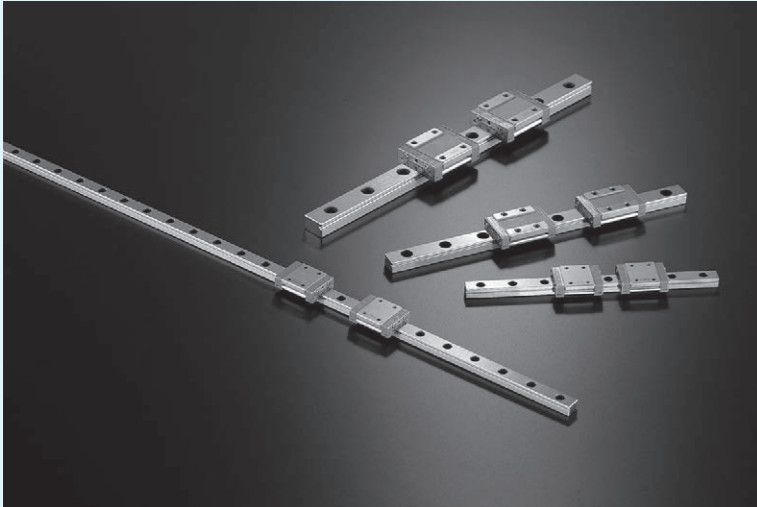

# C-Lube Linear Way MV

# MV



Long term maintenance free compliant!

The aquamarine end plate is the symbol of maintenance free.

Track rail

Slide unit

Casing

C-Lube

Ball

End plate

End seal

Ball retaining band

Grease nipple

MV30



## Points

### 1 Ultimate ball type linear motion rolling guide pursuing extra low profile and extra light weight

For details P.I-19

A linear motion rolling guide with extra low profile and extra light weight, achieved only because of the simple mechanism of two-row four-point contact structure.

### 2 High load capacity

Despite its extra low profile and extra light weight, it has the maximum load rating among the ball types and contributes to long life and increases safety of machine or device.

### 3 Long term maintenance free For details P.I-11

The built-in "C-Lube", the capillary lubricating element, in the ball circulation paths of the slide unit makes it long term maintenance free.

Lubrication oil is continuously supplied to the surface of rolling elements by surface tension in the contact of the capillary lubricating element surface and rolling elements.

### 4 Ball retained type for easy operation

The slide unit incorporates the ball retaining band, which prevents the ball from dropping down when the slide unit is removed from the track rail. This safety structure brings you an easy operation to the machines/equipment.

## Designation of Identification Number and Specification

### Example of an Identification Number

The specifications of the MV series are indicated by the identification number.

Indicate the identification number, consisting of a model code, dimensions, a part code, a preload symbol, a classification symbol, and any supplemental codes for each specification to apply.

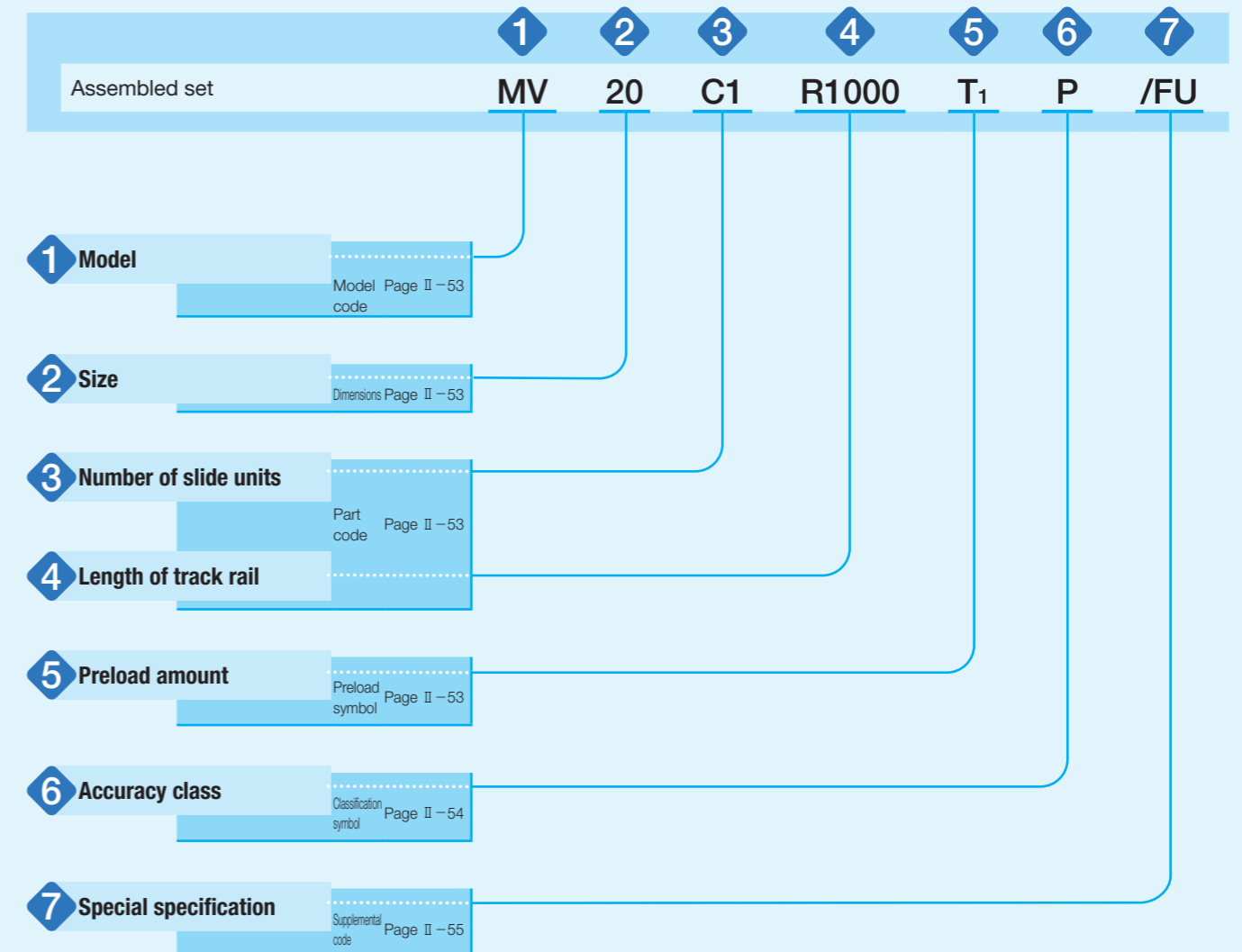

# Identification Number and Specification – Model · Size · Number of Slide Unit · Length of Track Rail · Preload amount –

<b>1 Model</b>	C-Lube Linear Way MV : MV (MV series)
<b>2 Size</b>	20, 25, 30
<b>3 Number of slide units</b>	: C○ Indicates the number of slide units assembled on a track rail.
<b>4 Length of track rail</b>	: R○ Indicate the length of track rail in mm. For standard and maximum lengths, see Table 1.

**Table 1 Standard and maximum lengths of track rail**

Item	MV 20	MV 25	MV 30
Standard length $L$ (n)	220 ( 4) 280 ( 5) 340 ( 6) 460 ( 8) 640 (11) 820 (14) 1 000 (17) 1 240 (21)	220 ( 4) 280 ( 5) 340 ( 6) 460 ( 8) 640 (11) 820 (14) 1 000 (17) 1 240 (21) 1 600 (27)	280 ( 4) 440 ( 6) 600 ( 8) 760 (10) 1 000 (13) 1 240 (16) 1 640 (21) 2 040 (26) 2 520 (32) 3 000 (38)
Pitch of mounting holes $F$	60	60	80
$E$	20	20	20
Standard $E$ or higher dimensions below	8 38	9 39	9 49
Maximum length <sup>(1)</sup>	2 200 (2 980)	2 980	3 000

unit: mm

Note <sup>(1)</sup> Length up to the value in ( ) can be produced. If needed, please contact IKO.  
Remark: If not directed,  $E$  dimensions for both ends will be the same within the range of  $E$  reference dimensions. To change the dimensions, indicate the specified rail mounting hole positions "/ $E$ " of special specification. For more information, see page III-30.

<b>5 Preload amount</b>	Clearance : T <sub>c</sub> Standard : No symbol Light preload : T <sub>1</sub>	For details of the preload amount, see Table 2.
-------------------------	--	---

**Table 2 Preload amount**

Preload type	Preload symbol	Preload amount N	Operational conditions
Clearance	T <sub>c</sub>	0 <sup>(1)</sup>	<ul style="list-style-type: none"> <li>Very light motion</li> <li>To absorb slight errors</li> </ul>
Standard	(No symbol)	0 <sup>(2)</sup>	<ul style="list-style-type: none"> <li>Light and precise motion</li> </ul>
Light preload	T <sub>1</sub>	0.02C <sub>0</sub>	<ul style="list-style-type: none"> <li>Almost no vibrations</li> <li>Load is evenly balanced</li> <li>Light and precise motion</li> </ul>

Notes <sup>(1)</sup> Clearance of about 10 μm  
<sup>(2)</sup> Indicates zero or minimal amount of preload.  
Remark: C<sub>0</sub> indicates the basic static load rating.

# – Accuracy Class –

<b>6 Accuracy class</b>	Ordinary : No symbol High : H Precision : P Super precision : SP	For details of accuracy class, see Table 3. For applicable combinations of accuracy class and preload amount, see Table 4.
-------------------------	---	---

**Table 3 Tolerance and allowance**

Class (Classification symbol)	Ordinary (No symbol)	High (H)	Precision (P)	Super precision (SP)
Dim. $H$ tolerance	±0.080	±0.040	±0.020	±0.010
Dim. $N$ tolerance	±0.100	±0.050	±0.025	±0.015
Dim. variation of $H$ <sup>(1)</sup>	0.025	0.015	0.007	0.005
Dim. variation of $N$ <sup>(1)</sup>	0.030	0.020	0.010	0.007
Parallelism in operation of the slide unit C surface to A surface	See Fig. 1.			
Parallelism in operation of the slide unit D surface to B surface	See Fig. 1.			

unit: mm

Note <sup>(1)</sup> It means the size variation between slide units mounted on the same track rail.

**Table 4 Combination of accuracy class and preload**

Item (preload symbol)	Ordinary (No symbol)	High (H)	Precision (P)	Super precision (SP)
Clearance (T <sub>c</sub> )	○	—	—	—
Standard (no symbol)	○	○	○	○
Light preload (T <sub>1</sub> )	—	○	○	○

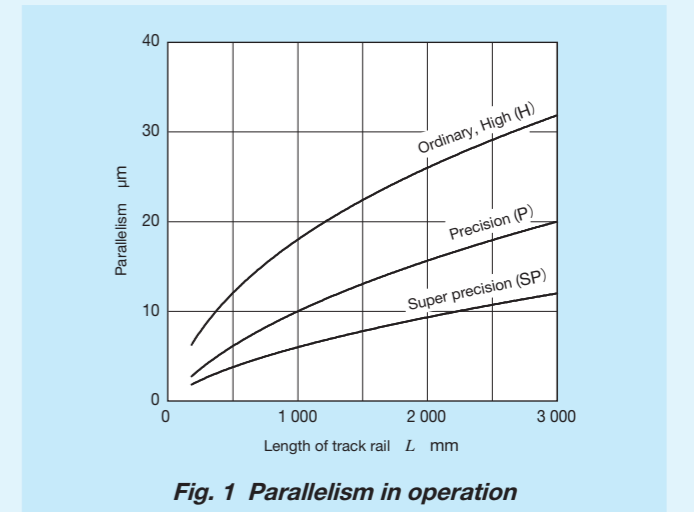

**Fig. 1 Parallelism in operation**

**7 Special specification**

/A, /D, /E, /F, /I, /LO, /LFO, /MA, /N, /U, /VO, /WO, /YCG, /ZO

For applicable special specifications, see Table 5.  
For combination of multiple special specifications, see Table 6.  
For details of special specifications, see page III-29.

**Table 5 Application of special specifications**

Special specification	Supplemental code
Butt-jointing track rails	/A
Opposite reference surfaces arrangement	/D
Specified rail mounting hole positions	/E
Caps for rail mounting holes	/F
Inspection sheet	/I
Black chrome surface treatment	/LO
Fluorine black chrome surface treatment	/LFO
With track rail mounting bolt	/MA
No seal	/N
Under seal	/U
Double seals	/VO
A group of multiple assembled sets	/WO
Specified grease (IKK Low Dust-Generation Grease for Clean Environment CG2)	/YCG
Scraper	/ZO

**Table 6 Combination of supplemental codes**

D	○																		
E	-	-																	
F	○	○	○																
I	○	○	○	○															
L	○	○	○	○	○														
LF	○	○	○	○	○	-													
MA	○	○	○	○	○	○	○												
N	○	○	○	○	-	○	○	○	○										
U	○	○	○	○	○	○	○	○	○	-									
V	○	○	○	○	○	○	○	○	○	○	-	○							
W	○	○	-	○	○	○	○	○	○	○	○	○	○						
YCG	○	○	○	○	○	○	○	○	○	○	○	○	○	○					
Z	○	○	○	○	○	○	○	○	○	-	○	○	○	○					
	A	D	E	F	I	L	LF	MA	N	U	V	W	YCG						

Remarks: 1. The combination of "-" shown in the table is not available.  
2. When using multiple types for combination, please indicate by arranging the symbols in alphabetical order.

**Table 7 Track rail mounting bolt size (Supplemental code /MA)**

Size	Bolt size for track rail
20	M5×14
25	M6×20
30	M6×20

Remark: Hexagon socket head bolts equivalent to JIS B 1176.

**Table 8  $H_1$  dimension with under seal (Supplemental code: /U)**

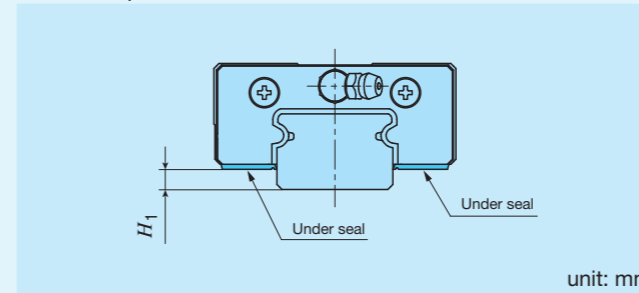

Size	$H_1$
20	4
25	4
30	4.5

**Table 9 Dimension of slide unit with double end seals (Supplemental code /V /VV)**

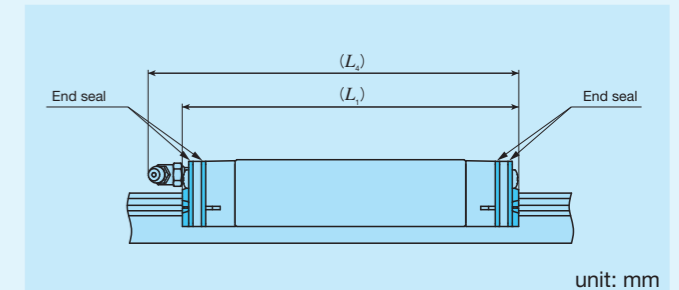

Size	$L_1$	$L_4$
20	81	83
25	101	111
30	125	141

Remark: The dimensions of the slide unit with double end seals at both ends are indicated.

**Table 10 Dimension of slide unit with scrapers (Supplemental code: /Z /ZZ)**

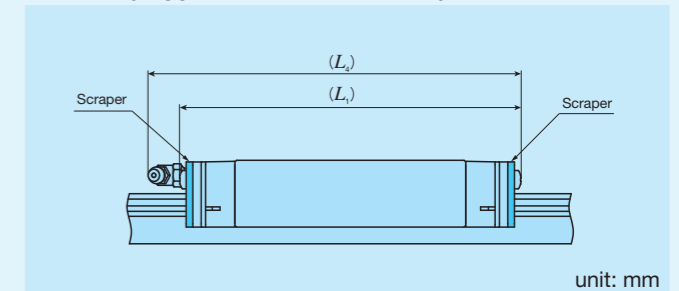

Size	$L_1$	$L_4$
20	82	84
25	103	112
30	127	142

Remark: The dimensions of the slide unit with scraper at both ends are indicated.

# Lubrication

Lithium-soap base grease with extreme-pressure additive (Alvania EP grease 2 [Shell Lubricants Japan K.K.]) is pre-packed in MV series. Additionally, MV series has C-Lube placed in the recirculation part of balls, so that the interval for reapplying lubricant can be extended and maintenance works such as grease job can be reduced significantly.

MV series has grease nipple as indicated in Table 11. Supply nozzles fit to each shapes of grease nipple are also available. When these parts are desired, see Tables 14.1 and 14.2 on page III-23 and Table 15 on page III-24 to order.

**Table 11 Parts for lubrication**

Size	Grease nipple type (1)	Applicable supply nozzle type	Bolt size of female threads for piping
20	A-M3	A-5120V A-5240V B-5120V B-5240V	—
25	B-M4	A-8120V B-8120V	M4
30	B-M6	Grease gun available on the market	M6

Note (1) For grease nipple specification, see Table 14.1 and 14.2 on page III-23.  
Remark: Stainless steel grease nipple is also available. If needed, please contact IKO.

# Dust Protection

MV Series slide units are equipped with end seals as standard for dust protection. However, if there is a great deal of contaminants or dust floating, or if large particles of foreign substances such as cutting chips or sand may adhere to the track rail, it is recommended to mount a protective cover on the linear motion mechanism.

It is also effective to use special options such as caps for rail mounting holes, under seals, double end seals and scrapers, depending on the use environment.

# Precaution for Use

## 1 Mounting surface, reference mounting surface and typical mounting structure

When mounting the MV series, properly align the reference mounting surface B and D of the track rail and slide unit with the reference mounting surface of the table and bed and fix them. (See Fig.2)

The reference mounting surfaces B and D and mounting surfaces A and C are precisely ground. Machining the mounting surface of the table and bed, such as machine or device, to high accuracy and mounting them properly will ensure stable linear motion with high accuracy.

Reference mounting surface of the slide unit is the opposite side of the IKO mark. The track rail reference mounting surface is identified by locating the IKO mark on the top surface of the track rail. It is the side surface above the mark (in the direction of the arrow). (See Fig.3)

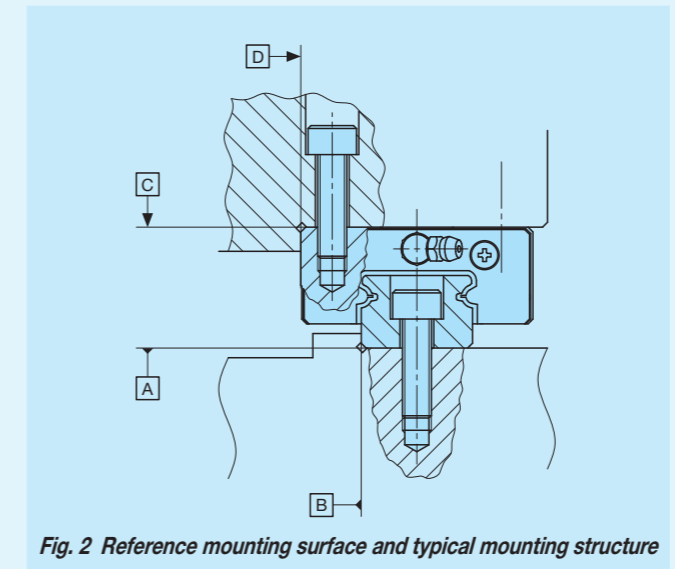

**Fig. 2 Reference mounting surface and typical mounting structure**

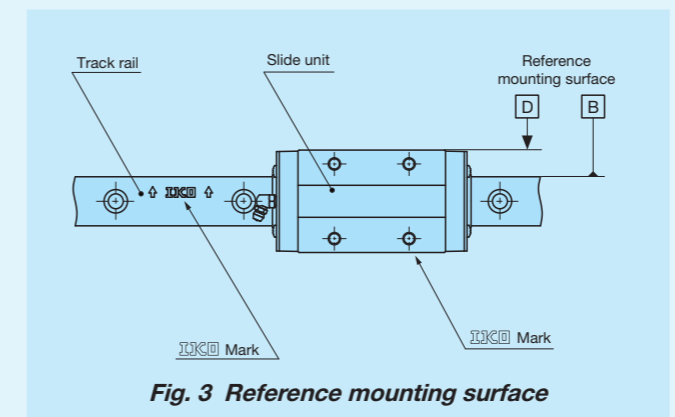

**Fig. 3 Reference mounting surface**

## 2 Shoulder height and corner radius of the reference mounting surface

For the opposite corner of the mating reference mounting, it is recommended to have relieved fillet as indicated in Fig.4. Recommended value for the shoulder height and corner radius on the mating side is indicated in Table 12.

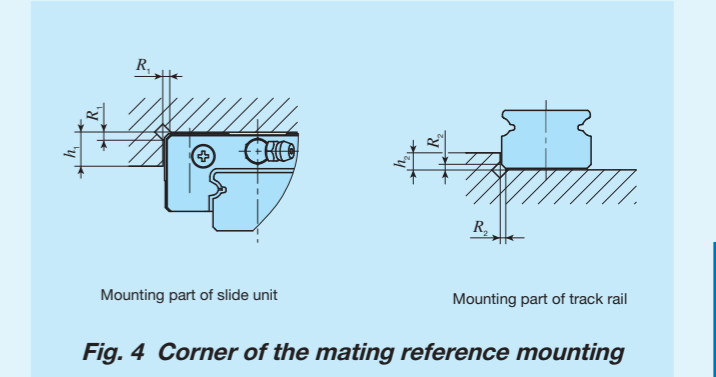

**Fig. 4 Corner of the mating reference mounting**

**Table 12 Shoulder height and corner radius of the reference mounting surface**

Size	Mounting part of slide unit		Mounting part of track rail	
	Shoulder height $h_1$	Corner radius $R_1$ (maximum)	Shoulder height $h_2$	Corner radius $R_2$ (maximum)
20	5	0.2	3	0.5
25	5	0.5	3	0.5
30	5	0.5	3	0.5

## 3 Tightening torque for fixing screw

Typical tightening torque for mounting of the MV series to the steel mating member material is indicated in Table 13. When vibration and shock of the machine or device are large, fluctuating load is large, or moment load is applied, fix it by using the torque 1.2 to 1.5 times larger than the value indicated in the table as necessary. If the mating member material is cast iron or aluminum alloy, reduce the tightening torque depending on the strength characteristics of the mating member material.

**Table 13 Tightening torque for fixing screw**

Bolt size	Tightening torque N · m	
	High carbon steel-made screw	Stainless steel-made screw
M5×0.8	8.0	5.0
M6×1	13.6	8.5
M8×1.25	32.7	20.4

Remark: The tightening torque is calculated based on strength division 12.9 and property division A2-70.

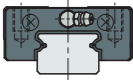
Standard type			
Shape	<b>MV</b>		
			
Size	20	25	30

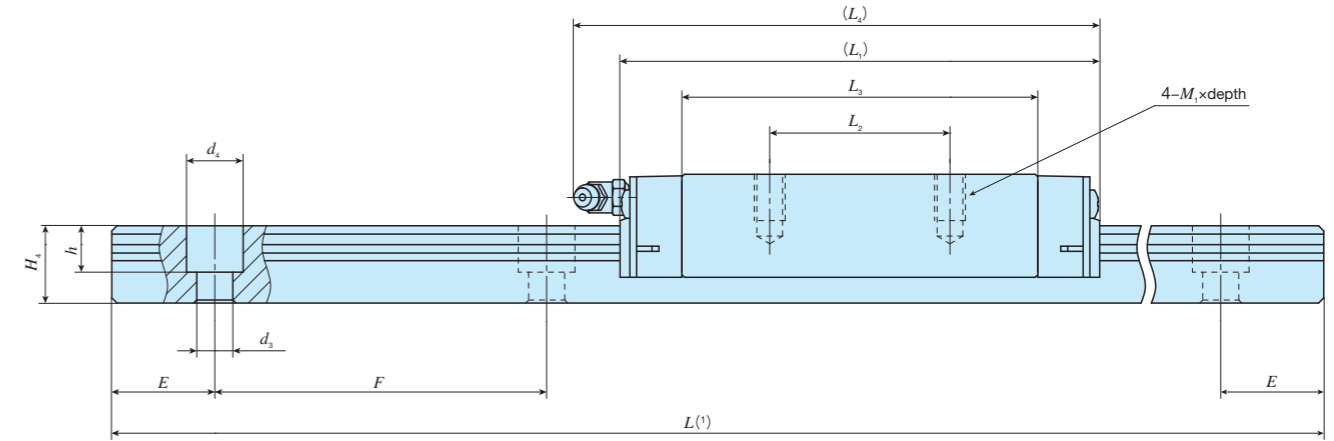
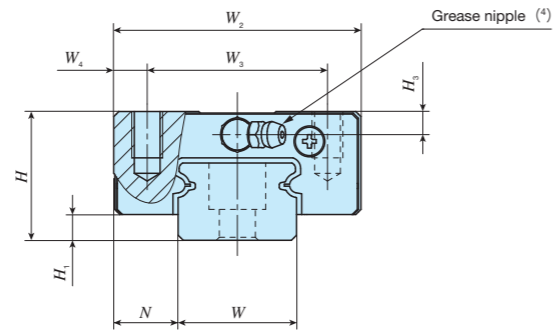

Identification number	Mass (Ref.)		Dimensions of assembly mm			Dimensions of slide unit mm									Dimensions of track rail mm							Appended mounting bolt for track rail (2) mm Bolt size × ℓ	Basic dynamic load rating (3) C N	Basic static load rating (3) C <sub>0</sub> N	Static moment rating (3)		
	Slide unit kg	Track rail kg/m	H	H <sub>1</sub>	N	W <sub>2</sub>	W <sub>3</sub>	W <sub>4</sub>	L <sub>1</sub>	L <sub>2</sub>	L <sub>3</sub>	L <sub>4</sub>	M <sub>1</sub> × depth	H <sub>3</sub>	W	H <sub>4</sub>	d <sub>3</sub>	d <sub>4</sub>	h	E	F				T <sub>0</sub> N · m	T <sub>x</sub> N · m	T <sub>y</sub> N · m
<b>MV 20</b>	0.18	1.66	20	5	11	42	32	5	73	32	51.2	76	M5×6	3.5	20	12	6	9.5	8.5	20	60	M5×14	19 600	25 600	138	115 624	102 555
<b>MV 25</b>	0.36	2.37	25	5	12.5	48	35	6.5	94	35	69.1	103	M6×9	4.5	23	15	7	11	9	20	60	M6×20	31 900	42 500	264	260 1 320	230 1 170
<b>MV 30</b>	0.72	3.33	30	6	16	60	40	10	116	40	86.6	126	M8×11	5	28	17	7	11	9	20	80	M6×20	46 300	61 800	468	467 2 350	414 2 090

Notes (1) Track rail lengths  $L$  are shown in Table 1 on page II-53.  
 (2) Track rail mounting bolts are not appended. Hexagon socket head bolts of JIS B 1176 with strength division 12.9 are recommended.  
 (3) The direction of basic dynamic load rating ( $C$ ), basic static load rating ( $C_0$ ), and static moment rating ( $T_0$ ,  $T_x$ ,  $T_y$ ) are shown in the sketches below. The upper values of  $T_x$  and  $T_y$  are for one slide unit and the lower values are for two slide units in close contact.  
 (4) For specifications of grease nipple, see Table 11 on page II-57.

### Example of identification number of assembled set

Model code: **MV**    Dimensions: **25**    Part code: **C2**    Preload symbol: **R1000**    Classification symbol: **T<sub>1</sub>**    Supplemental code: **SP**    **/FU**

① Model  
MV C-Lube Linear Way MV

② Size  
20, 25, 30

③ Number of slide units (2)

④ Length of Track Rail (1000mm)

⑤ Preload amount	
T <sub>c</sub>	Clearance
No symbol	Standard
T <sub>1</sub>	Light preload

⑥ Accuracy class	
No symbol	Ordinary
H	High
P	Precision
SP	Super precision

⑦ Special specification  
A, D, E, F, I, L, LF, MA, N, U, V, W, YCG, Z

